

TRU/FLO® Compound Parts List

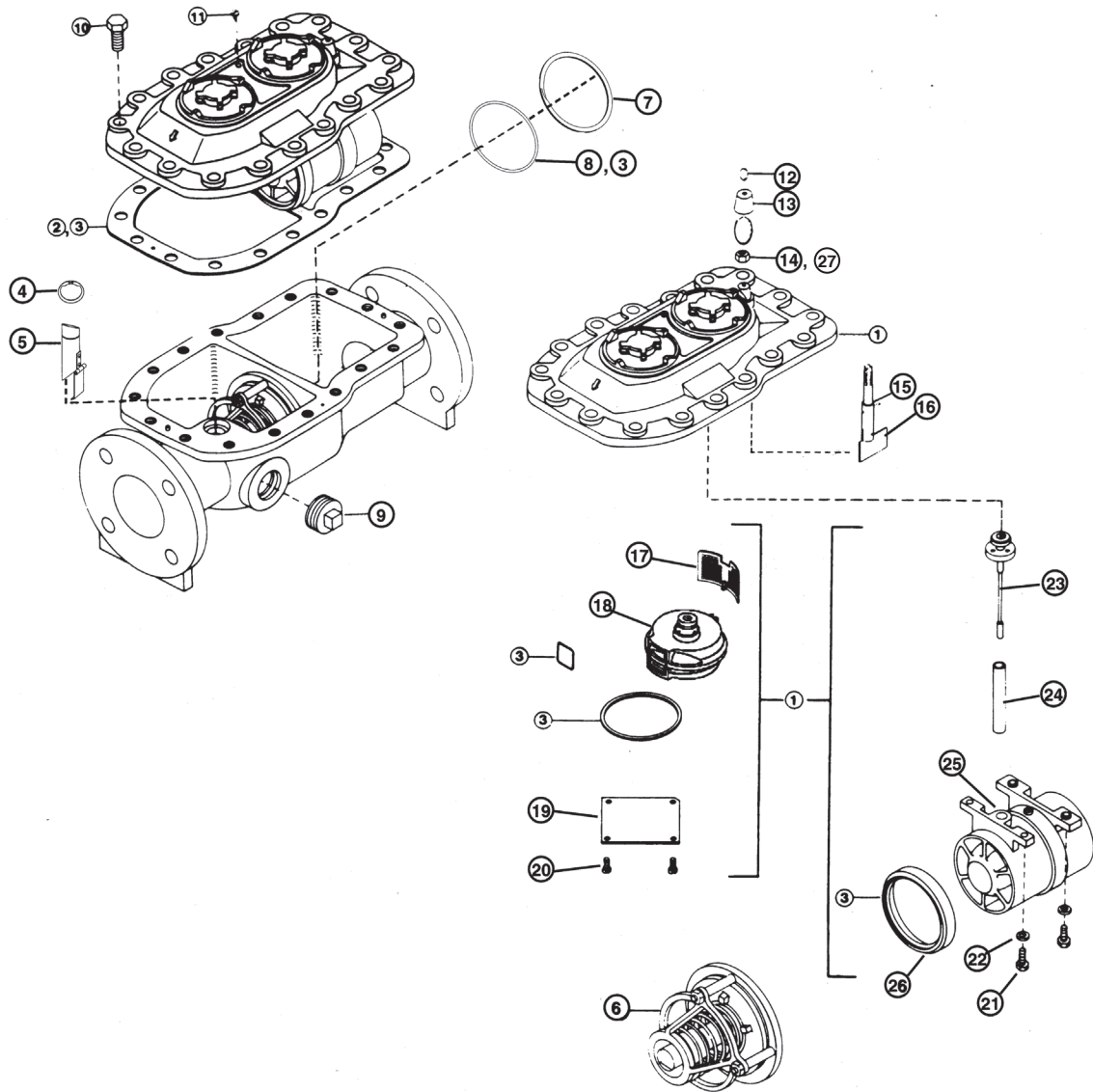

ITEM	DESCRIPTION	METER SIZE & PART NUMBERS		
		3"	4"	6"
1	Cover Assembly	9409-003	9565-100	9566-100
2	Maincase Gasket	8341-312	8341-313	8341-314
3	Maincase Gasket Kit	9685-001	9685-002	9685-003
4	Snap Ring	8579-033	8579-034	8579-036
5	Throttle Valve Assembly	9571-110	9571-200	9571-300
6	Main Valve Assembly	9403-120*	9403-121	9403-122
7	Main Valve Snap Ring	8579-305	8579-306	8579-307
8	O-Ring	8316-274	8316-276	8316-275
9	Pipe Plug	8315-027(2)	8315-028	8315-028
10	Bolt Cover	8329-405	8329-405	8329-421
11	Vent Screw	8394-003	8394-003	8394-003
12	Seal Wire with Lead Seal	41110-501	41110-501	41110-501
13	Seal Cap	11098-001	11098-001	11098-001
14	Calibration Nut	8545-417	8545-417	8545-417
15	O-Ring	8316-022	8316-022	8316-022
16	Calibration Vane Assembly	11097-600	11097-700	11097-800
17	T-10® Strainer	9399-002	9831-001	9831-002
18	T-10 Chamber	9400-600	9826-200	9826-300
19	Plate	9406-001	9406-002	9406-003
20	Screw	8305-042	8329-006	8329-114
21	Bolt	8329-007	8329-007	8329-206
22	Washer, Lock	8564-211	8564-211	8564-212
23	Drive Assembly	9485-006	9485-003	9485-008
24	Drive Sleeve	9484-008	9484-009	9484-010
25	Measuring Chamber Assembly	9439-001SP00	9439-002SP00	9439-106
26	Seal Ring	8340-063	8340-064	8340-065
27	Washer, Lock	8564-211	8564-211	8564-211

*This part is only available in a kit. P/N 9681-001



ITEM	DESCRIPTION	METER SIZE & PART NUMBER
		2" HP
1	Cover Assembly	9676-100
2	Maincase Gasket	9675-001
3a	Throttle Valve Door	9679-001
3b	Throttle Valve Seat	9680-001
4	Main Valve Assembly	9669-000
5	Screw, Retainer	8328-045
6	Retainer Ring	9674-001
7	O-Ring, Retainer	8316-041
8	Strainer	9855-001
9	Locking Ring	9856-001
10	Pipe Plug	8315-027(2)
11	Bolt, Cover	8329-213
12	Spirol Pin	8350-008
13	Vent Screw	8394-003
14	Seal Wire with Lead Seal	41110-501
15	Seal Cap	13349-001
16	Calibration Nut	8545-417
17	O-Ring	8316-022
18	Calibration Vane Assembly	11097-610
19	Maincase Gasket Kit	9685-004
20	T-10 Chamber	9400-600
21	T-10 Strainer	9399-002
22	Drive Assembly	9485-011
23	Drive Sleeve	9484-013
24	2" HP Turbine Strainer	9399-003
25	Chamber Plate	9678-001
26	Screw	8396-007
27	Measuring Assembly	9861-000
28	Bolt	8305-042
29	Washer, Lock	8654-210
30	Seal Ring	8340-062
31	Washer, Lock	8654-211

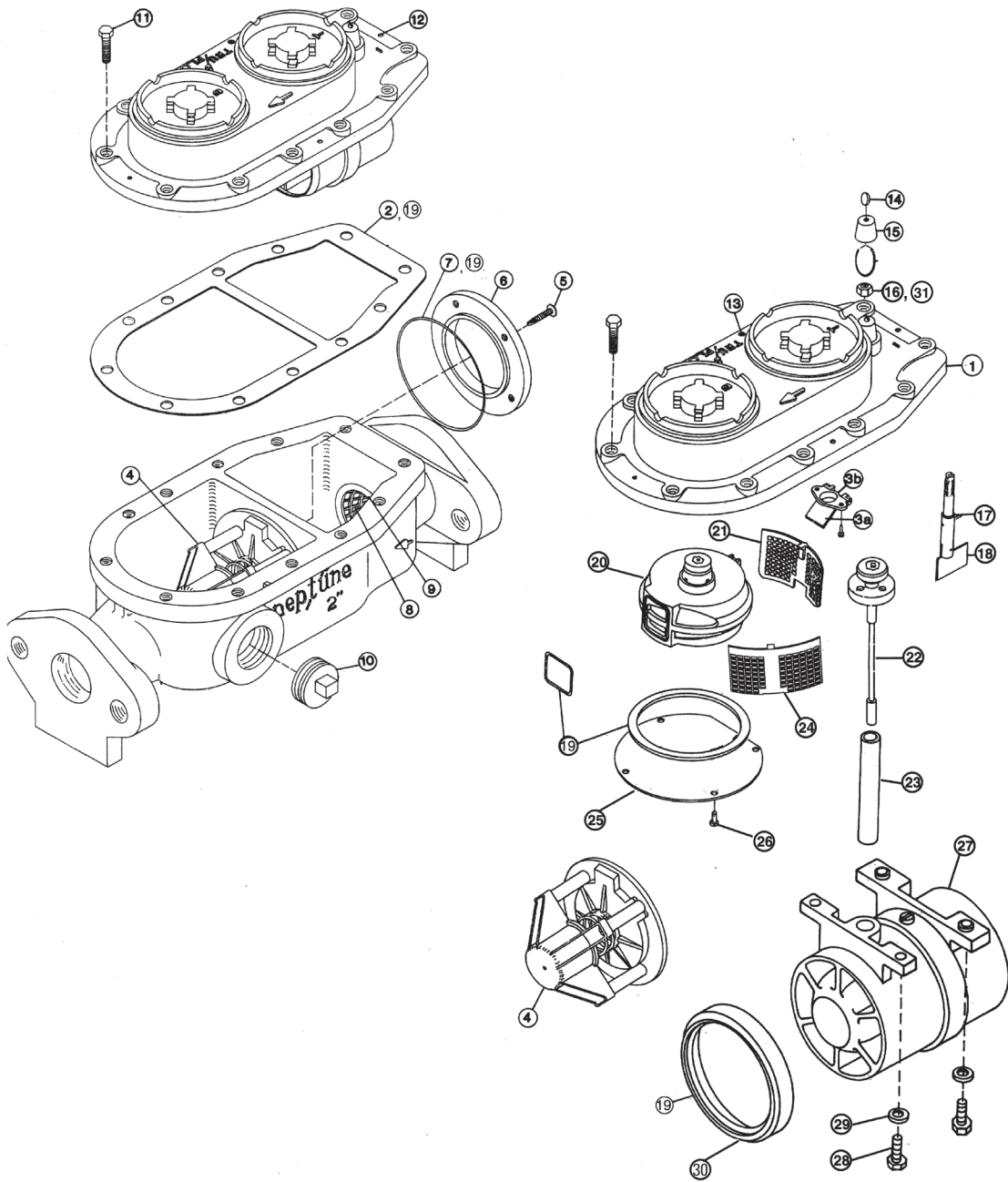

(UME INCLUDES: TWO REGISTERS, GASKET, AND COVER ASSEMBLY)

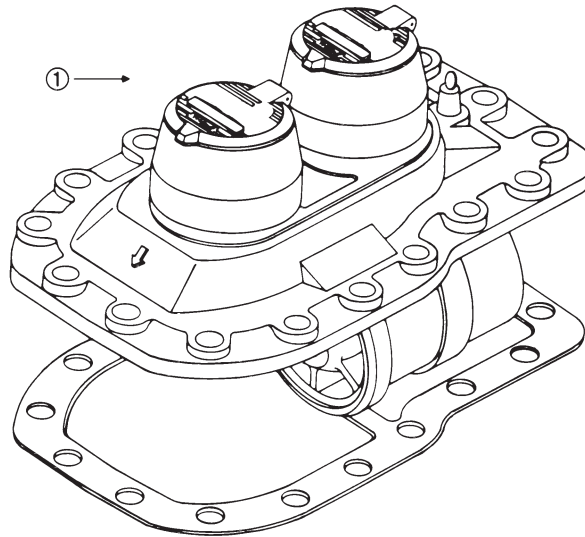

SIZE	REGISTRATION	(1) DIRECT READ		
		DISC REGISTER	TURBINE REGISTER	UME
2" HP	Cu. Ft.	R82F12	R85F1	9730-010
	Gal.	R82G12	R85G1	9730-020
	M ³	R82M12	R85M1	9730-040
2"	Cu. Ft.	R82F12	R83F2	N/A
	Gal.	R82G12	R83G2	N/A
	M ³	R82M12	R83M2	N/A
3"	Cu. Ft.	R82F12	R83F2	9596-110
	Gal.	R82G12	R83G2	9596-120
	M ³	R82M12	R83M2	9596-140
4" w/T-8 Register	Cu. Ft.	R81F22	R83F3	N/A
	Gal.	R81G22	R83G3	N/A
	M ³	R81M22	R83M3	N/A
6" w/T-8 Register	Cu. Ft.	R81F32	R83F4	N/A
	Gal.	R81G32	R83G4	N/A
	M ³	R81M32	R83M4	N/A
4" w/T-10 Register	Cu. Ft.	R82F22	R83F3	9596-210
	Gal.	R82G22	R83G3	9596-220
	M ³	R82M22	R83M3	9596-240
6" w/T-10 Register	Cu. Ft.	R82F32	R83F4	9596-310
	Gal.	R82G32	R83G4	9596-320
	M ³	R82M32	R83M4	9596-340

Note: When ordering registers, please include change gear combination or four-digit register code from dial face.

(UME INCLUDES: TWO REGISTERS, GASKET, AND COVER ASSEMBLY)

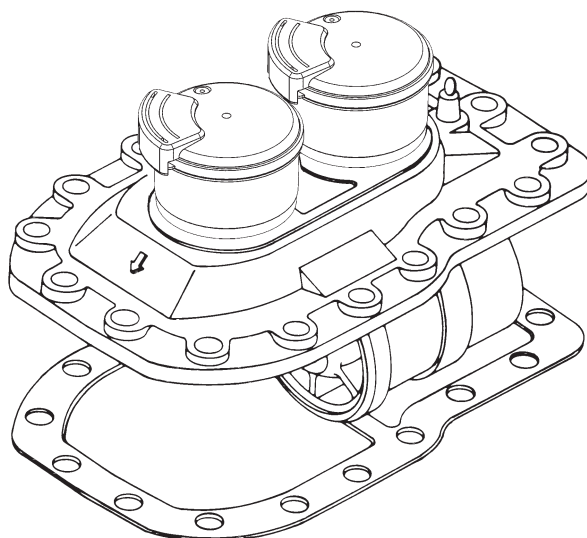

SIZE	REGISTRATION	ProRead™ (Pit) 4-Wheel Encoder*			ProRead™ (Pit) 6-Wheel Encoder*			E-CODER® (Pit)			E-CODER®/R900i™ (Pit)		
		DISC	TURBINE		DISC	TURBINE		DISC	TURBINE		DISC	TURBINE	
		REGISTER	REGISTER	UME	REGISTER	REGISTER	UME	REGISTER	REGISTER	UME	REGISTER	REGISTER	UME
2" HP	Cu. Ft.	R78F11	R75F11	9730-018	R78F12	R75F12	9730-019	RH8F11	RH5F11	9730-011	RW8F11	RW5F11	9730-050
	Gal.	R78G11	R75G11	9730-028	R78G12	R75G12	9730-029	RH8G11	RH5G11	9730-021	RW8G11	RW5G11	9730-060
	M³.	R78M11	R75M11	9730-048	R78M12	R75M12	9730-049	RH8M11	RH5M11	9730-041	RW8M11	RW5M11	9730-080
2"	Cu. Ft.	R72F11	R73F11	N/A	R72F12	R73F12	N/A	RH8F11	RH3F11	N/A	RW8F11	RW3F11	N/A
	Gal.	R72G11	R73G11	N/A	R72G12	R73G12	N/A	RH8G11	RH3G11	N/A	RW8G11	RW3G11	N/A
	M³.	R72M11	R73M11	N/A	R72M12	R73M12	N/A	RH8M11	RH3M11	N/A	RW8M11	RW3M11	N/A
3"	Cu. Ft.	R78F11	R73F21	9596-111	R78F12	R73F22	9596-118	RH8F11	RH3F21	9596-119	RW8F11	RW3F21	9596-150
	Gal.	R78G11	R73G21	9596-121	R78G12	R73G22	9596-128	RH8G11	RH3G21	9596-129	RW8G11	RW3G21	9596-160
	M³.	R78M11	R73M21	9596-141	R78M12	R73M22	9596-148	RH8M11	RH3M21	9596-149	RW8M11	RW3M21	9596-180
4" w/T8 Register	Cu. Ft.	R71F21	R73F31	N/A	R71F22	R73F32	N/A	RH1F21	RH3F31	N/A	RW1F21	RW3F31	N/A
	Gal.	R71G21	R73G31	N/A	R71G22	R73G32	N/A	RH1G21	RH3G31	N/A	RW1G21	RW3G31	N/A
	M³.	R71M21	R73M31	N/A	R71M22	R73M32	N/A	RH1M21	RH3M31	N/A	RW1M21	RW3M31	N/A
6" w/T8 Register	Cu. Ft.	R71F31	R73F41	N/A	R71F32	R73F42	N/A	RH1F31	RH3F41	N/A	RW1F31	RW3F41	N/A
	Gal.	R71G31	R73G41	N/A	R71G32	R73G42	N/A	RH1G31	RH3G41	N/A	RW1G31	RW3G41	N/A
	M³.	R71M31	R73M41	N/A	R71M32	R73M42	N/A	RH1M31	RH3M41	N/A	RW1M31	RW3M41	N/A
4" w/T10 Register	Cu. Ft.	R78F21	R73F31	9596-211	R78F22	R73F32	9596-218	RH8F21	RH3F31	9596-219	RW8F21	RW3F31	9596-250
	Gal.	R78G21	R73G31	9596-221	R78G22	R73G32	9596-228	RH8G21	RH3G31	9596-229	RW8G21	RW3G31	9596-260
	M³.	R78M21	R73M31	9596-241	R78M22	R73M32	9596-248	RH8M21	RH3M31	9596-249	RW8M21	RW3M31	9596-280
6" w/T10 Register	Cu. Ft.	R78F31	R73F41	9596-311	R78F32	R73F42	9596-318	RH8F31	RH3F41	9596-319	RW8F31	RW3F41	9596-350
	Gal.	R78G31	R73G41	9596-321	R78G32	R73G42	9596-328	RH8G31	RH3G41	9596-329	RW8G31	RW3G41	9596-360
	M³.	R78M31	R73M41	9596-341	R78M32	R73M42	9596-348	RH8M31	RH3M41	9596-349	RW8M31	RW3M41	9596-380

*Registers do not include ARB® remote receptacles.

Note: When ordering registers, please include change gear combination or four-digit register code from dial face.

Neptune Technology Group Inc.

1600 Alabama Highway 229

Tallassee, AL 36078

USA

Tel: (800) 645-1892

Fax: (334) 283-7293

Neptune Technology Group (Canada) Ltd.

7275 West Credit Avenue

Mississauga, Ontario

L5N 5M9

Canada

Tel: (905) 858-4211

Fax: (905) 858-0428

Neptune Technology Group Inc.

Avenida Ejercito Nacional No 418

Piso 12, Despacho 1203

Colonia Polanco V Sección

C.P. 11560

Delegación, Miguel Hidalgo

Mexico D.F.

Tel: (525) 5203-4032 / (525) 5203-6204

(525) 5203-5294

Fax: (525) 5203-6503

NEPTUNE
TECHNOLOGY GROUP

neptunetg.com