

AMI Your Way

Neptune® R900® System: Cellular Endpoint



Neptune's cellular endpoint allows you to progress at your own pace to AMI when integrated into your Neptune® R900® System. Neptune's cellular endpoint provides all of the benefits of an advanced meter reading solution without the operational burden of network infrastructure while allowing you to protect existing asset investments. An easily deployable AMI solution, the cellular endpoint allows you to start collecting actionable meter data immediately. You are assured a reliable, highly secure, and easy-to-deploy cellular AMI data solution for both current and future needs.

- No AMI fixed network infrastructure installation, maintenance, operations, or upgrade costs for the life of the deployment.
- Seamlessly integrates with existing R900 technology for a flexible AMI solution.
- Access all of your meter data from anywhere at any time with Neptune® 360™.
- Improve operations and customer service with real-time, high-resolution AMI data and advanced analytics.
- Automatically recover from network outages with 96 days of stored data.
- Two-way solution using LTE-M cellular technology helps ensure robust coverage.
- Maximized coverage with any of Canada's cellular networks.
- Sensitive information is highly secure.

Specifications

Environmental Conditions

- Operating temperature:
-22°F to +149°F (-30°C to +65°C)
- Storage temperature:
-40°F to +158°F (-40°C to +70°C)
- Operating humidity: 100%
condensing

Antennas

- Wall: standard internal antenna
- Pit: internal or external antenna

Encoded Register Compatibility

- Neptune® MACH 10®, ARB®V,
ProRead™, E-CODER®, and
ProCoder™
- Sensus ECR II, ICE, iPerl,
Electronic Register and OMNI
- Hersey/Mueller Translator
- Badger ADE, HR E|LCD, E-Series
- Elster/AMCO InVision (Sensus
protocol version)

Operation

- Regular cellular LTE-M
transmissions with configurable
transmission windows
- Mobile 900 MHz backup
transmissions
- Verify installation via the cellular
endpoint manager tool
- 15-minute interval data with
automatic back-fill
- Priority alerts

Warranty

- Neptune provides a limited
warranty for performance,
materials, and workmanship.
See warranty statement for details.

Dimensions

Wall Endpoint

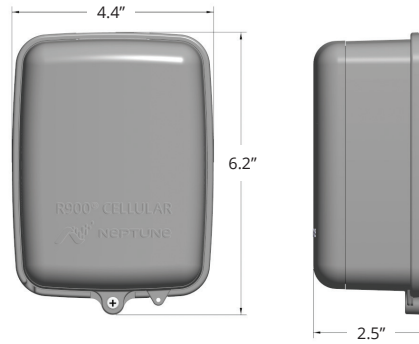

Pit Endpoint (Internal Antenna)

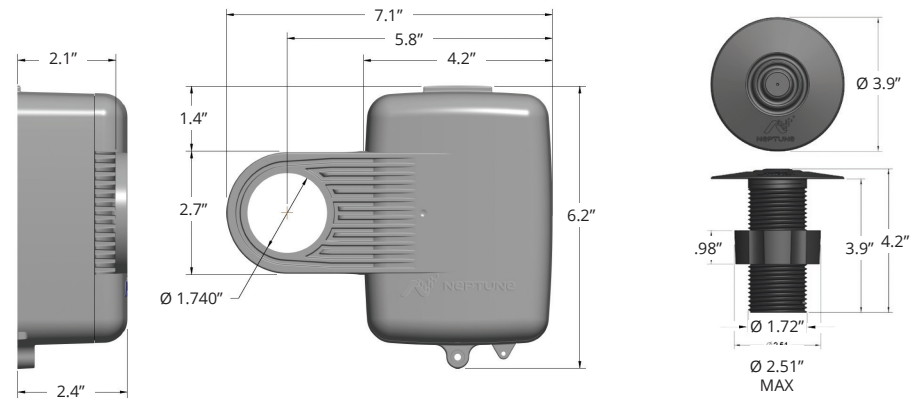

Pit Endpoint with External Through-the-Lid Antenna

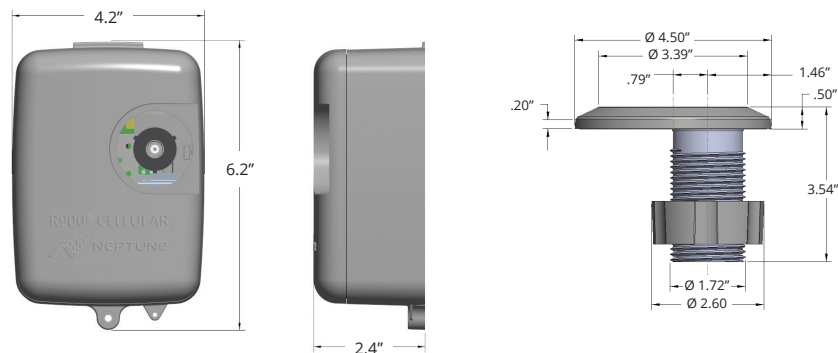

Neptune Technology Group
1600 Alabama Highway 229
Tallahassee, AL 36078
800-633-8754 f 334-283-7293